



TTi Performance Exhaust and Headers
 Tube Technologies, Inc.
 Corona, California 92880-1726
 Phone (951) 371-4878
www.ttiexhaust.com

Header P/N: TTi 440-214, TTi 440-218

HEADER INSTALLATION

Parts List	Sheets attached
(1) Driver side header	#101
(1) Passenger side header	#3703
(2) Header gaskets	#708MC / #708WA
(12) 3/8"-16x1 Header bolts	
(2) Header reducer adapters w/ 3.5" 3-bolt collector flange	
(2) 3.5" 3-bolt gaskets	
(6 sets) 3/8" bolts, washers & nuts	

Thank you for choosing TTi Performance Headers!

Due to the numerous engine configurations and suspension combinations, we cannot ensure headers and exhaust to fit all combinations, however, we have done our best to accommodate both factory and aftermarket component combinations. e.g. Engine blocks, cylinder heads, starters, valve covers, etc.

For further product details, footnotes & fitment information, please visit our website www.ttiexhaust.com or call (951)371-4878.

BEFORE STARTING

READ the entire installation instructions and understand each of the steps involved with the installation. Review all modification sheets and/or diagrams.

CAUTION - Allow time for vehicle to cool down prior to the installation. Wear protective safety equipment; Eye goggles and gloves.

Use an appropriate lifting device to raise the vehicle; Floor hoist or hydraulic floor jack with jack stands. Do not use bumper jacks!

WARNING - We strongly suggest that you use an old set of headers or a set of cast iron manifolds for first engine runs / cam break-ins to avoid coating damage. Excessive heat damage to the ceramic coating will void all warranties. Header coating damage usually occurs during the first engine run when the exhaust temperatures exceed 1200°F. Excess exhaust temperatures are normally caused by excessively lean or excessively rich air/fuel mixtures and/or incorrect ignition timing.

CHECK your engine location - All K-members are not identical and the dimensions must be checked to ensure proper fitment of the headers or exhaust system. If the engine is not located correctly in the chassis our products will not fit properly. If necessary place shims between the insulator assembly and the K-frame mounting pad to achieve the proper factory dimensions.

Shims: For small position adjustments, shim packs are available through Schumacher Creative Services of Seattle, WA.

From the center of the crankshaft to the top of the K-frame the correct distance is **(A)**. The engine is also offset towards the passenger-side **(B)**. Measure from the center of the crankshaft to each frame rail, the difference should be **(C)**.

Factory Engine Locations – B/RB	A (inches)	B (inches)	C (inches)
67-76 A-body	5-1/4	1-1/4	2-1/2
62-65 B-body	5-1/4	1-1/2	3
66-74 B-body	5-1/4	1-1/4	2-1/2
70-74 E-body	5-1/4	1-1/4	2-1/2



TTi Performance Exhaust and Headers
Tube Technologies, Inc.
Corona, California 92880-1726
Phone (951) 371-4878
www.ttiexhaust.com

Header P/N: TTi 440-214, TTi 440-218

HEADER INSTALLATION

Page 2 of 3

SUSPENSIONS

62-74 B-bodies & 70-74 E-bodies: OEM suspensions with torsion bars or coilover suspension systems without torsion bars O.K.

DISASSEMBLY

1. Disconnect the negative cable from the battery terminal.
2. Raise the front of the vehicle with an appropriate lifting device and place on jack stands.
3. Disconnect the plug wires and remove all of the spark plugs.
4. Remove the cast iron manifolds and the stock exhaust pipes. If you're replacing the exhaust system, remove the entire exhaust, including hangers.
5. Drain the engine coolant into a suitable container before removing the exhaust studs from the cylinder heads.
6. Disconnect the electrical cables to the starter and remove the starter motor.
7. **Standard Transmission:** Disconnect and remove the Z-bar. The Z-bar will be reinstalled after the header is in place.
8. Remove the oil stick tube.
9. **Automatic Transmission:** Applications with a three (3) section throttle rod will require modification to the swivel assembly to clear the header tubes. [See sheet #101]
No modification required on models with the single section transmission throttle rod.
10. **Automatic Trans / Floor Shift:** B & E-body applications will require repositioning the adjustable swivel and the lower rod attached to the shift lever to clear the header collector. [See sheet #3703]
11. Now is a good time to check the condition of your engine mounts. If they are worn or deteriorated, replace them now. When the engine is mounted correctly the headers will fit correctly.

PASSENGER-SIDE INSTALLATION

12. Check the cylinder head sealing surface of the exhaust ports to insure they are clean. Place the supplied header gasket onto position on the studs. Turn steering wheel to the full left position. Insert the header into position from under the car. Use the provided header bolts to secure the header to the cylinder head. Tighten the center bolts first, then the end ports. Torque the bolts to 35 lbs. evenly to insure a proper seal.

B & E-body applications - The original studs and nuts may be used to secure the header to the cylinder head. However, the second (2nd) stud from the front must be shortened for the tube clearance on both sides. It may also be necessary to raise the engine when using the original studs.

Recommendation when installing header gaskets: Use a very thin layer of High-Temp Silicone Sealer on each side of gasket.



TTi Performance Exhaust and Headers
Tube Technologies, Inc.
Corona, California 92880-1726
Phone (951) 371-4878
www.ttiexhaust.com

Header P/N: TTi 440-214, TTi 440-218

HEADER INSTALLATION

Page 3 of 3

DRIVER-SIDE INSTALLATION

13. Remove the engine mount bolt and raise the engine up approximately 1-1/2". Use a block of wood between the oil pan and the floor jack. Turn the steering wheel to full right position.

14. Check the sealing surface of the exhaust ports to insure that they are clean. Place the supplied header gasket into position on the studs. Insert the header into position from under the car.

Before fastening the header to the cylinder head, place the starter motor into position and tighten the fasteners.

Recommendation when installing header gaskets: Use a very thin layer of High-Temp Silicone Sealer on each side of gasket.

15. Lower the engine back down on to the K-frame and re-install the engine mount bolt.

16. Now, secure the header to the cylinder head using the provided header bolts. Tighten the center bolts first, then the end ports. Torque the bolts to 35 lbs. evenly to insure a proper seal.

17. Connect the wiring to the starter. Adjust the wiring to insure that there is absolutely no contact with the header tubes. A minimum of 3/8" clearance is required between the header and the wiring.

18. Brake Lines - Due to variations in the routing of brake lines, it may be necessary to re-position a brake line to achieve adequate clearance from tubes. A minimum clearance of 1/2" from a header tube is required.

19. Insert the oil stick tube into position. Some designs fit between the header flange and the #1 cylinder tube, some fit outside of the #1 header tube. Slight bending may be required for proper fit.

20. **Re-Install** the clutch Z-bar, the spark plugs, wires and engine coolant.

21. **Re-connect** the negative battery cable.

22. To transition headers to your exhaust system, attach the supplied **Header reducer adapters** directly to the 3-bolt header collectors using the provided nuts, bolts and gaskets.

FINAL STEPS

23. Now that your headers are installed, wipe down the tubes with hot soapy water or an environmentally safe Orange Cleaner Degreaser and a soft cloth to remove any grease or skin oils (finger prints) from the header tube surface. Never use abrasive cleaners.

To insure years of service from your headers follow our Maintenance & Care instructions.

24. Start the engine and check for leaks.

25. Re-torque all of the header bolts after approximately 50 miles of driving.



TTI Performance Exhaust and Headers
Tube Technologies, Inc.
Corona, California 92880-1726
Phone (951) 371-4878

www.ttiexhaust.com

Sheet #101 / Footnote #36

3-section throttle rod swivel assembly modification

Applications with a 3-section throttle rod may require modification to the bell-crank and the pivot shaft to clear the header tubes or exhaust pipes.

Big Block Headers: Modification may be required when installing some headers.

Exhaust-pipes (to stock manifolds): Modification will be required when installing listed pipes; A25LE, E25LE3 and E30LE3.

1. The bell-crank and the pivot shaft must be shortened by 3/4".
2. Weld the bell-crank back together as shown.
3. Re-bend the lower throttle rod as shown.

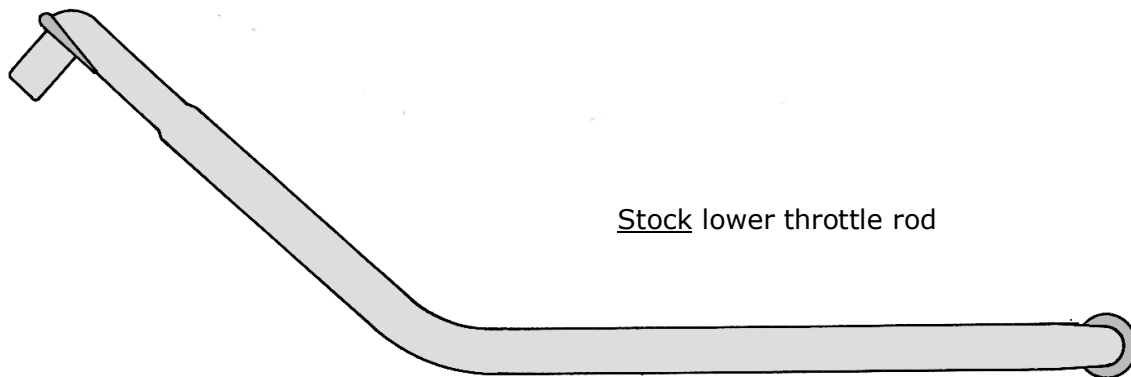
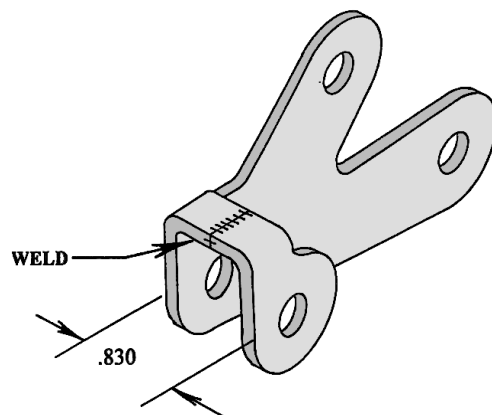

Stock lower throttle rod

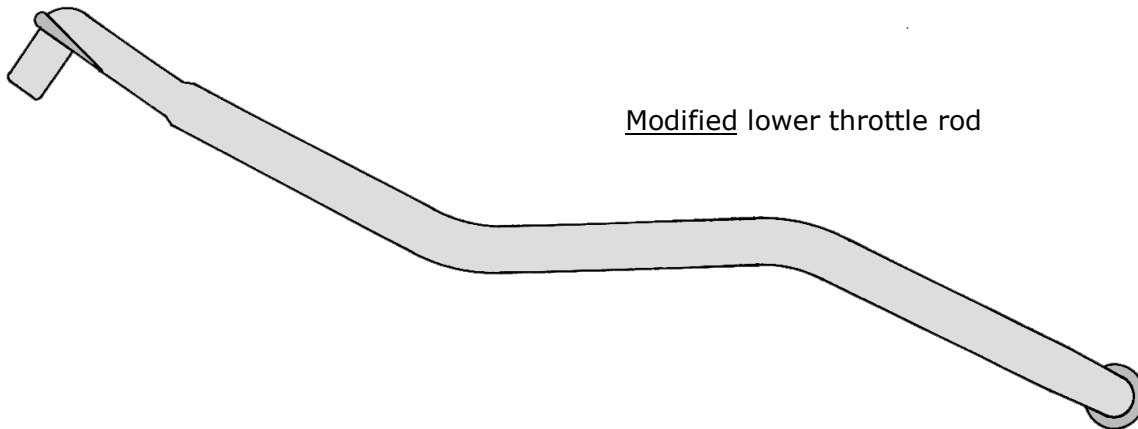

Modified lower throttle rod



TTI Performance Exhaust and Headers
Tube Technologies, Inc.
Corona, California 92880-1726
Phone (951) 371-4878

www.ttiexhaust.com

Sheet #3703 / Footnote #23

TORQUE SHAFT LEVER REPOSITIONING Auto Trans with Floor Shift

Automatic Transmission with Floor Shifter will require repositioning of the adjustable swivel and lower rod attached to the torque shaft lever. Move them to the upper side of the torque shaft lever to clear the header collector. Some models will require additional modification for clearance of the shifting lever. (See diagram)

The support bracket is cut through and overlapped approximately 1/4" and re-welded, making it shorter and moving the shift lever away from the collector.

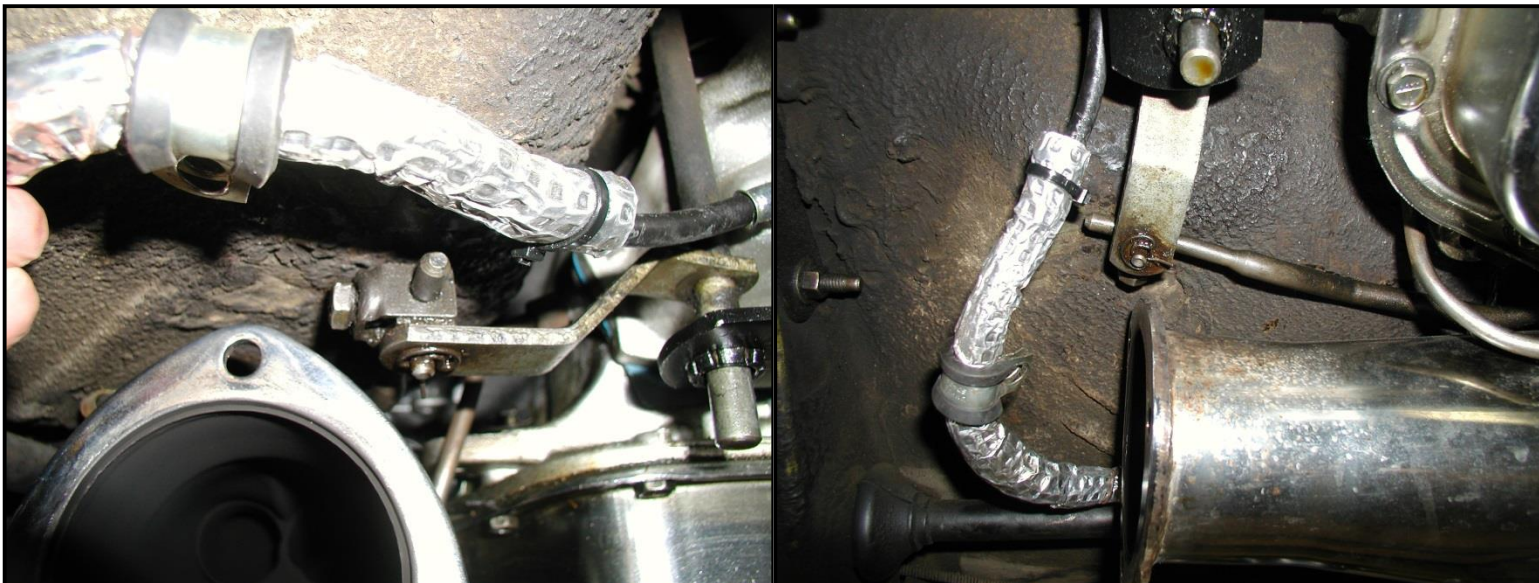
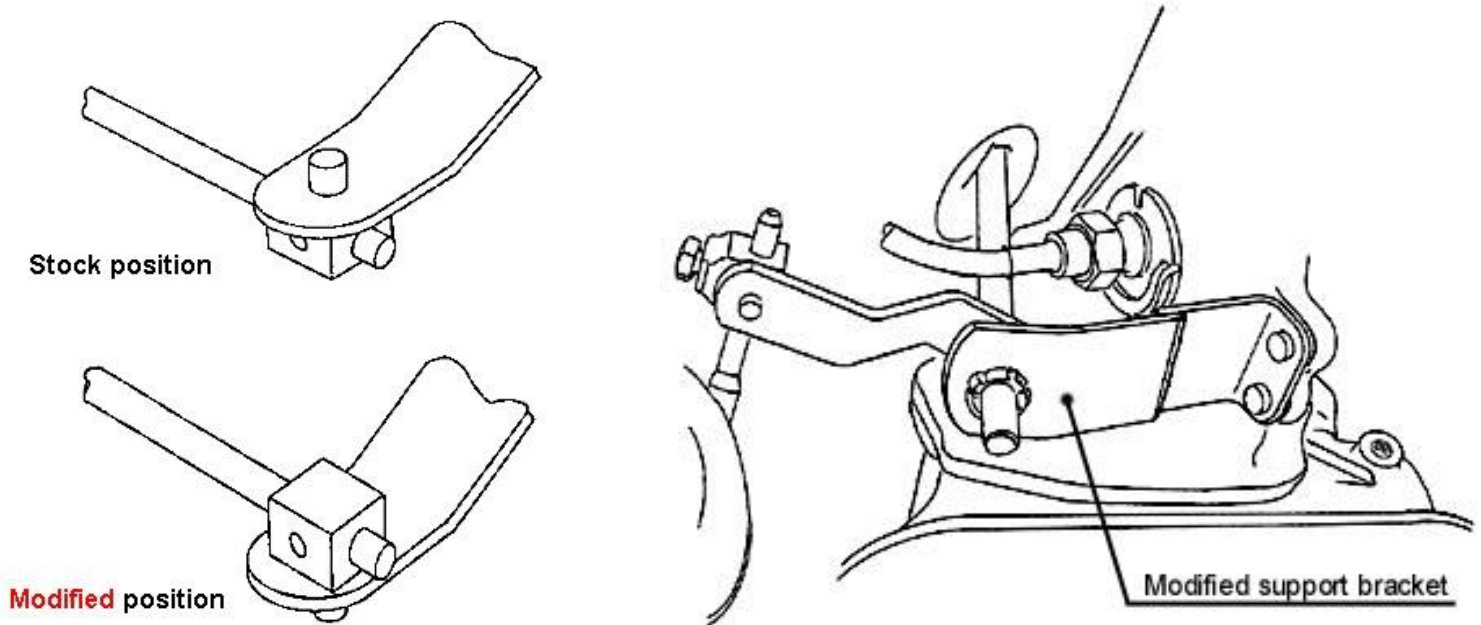



(!) CERAMIC COATING FACT

Ceramic coating is a very durable finish compared to other finishes however; it does not eliminate the risk of scratches during installation, rock chips made by road debris, swirl marks, and water spots. Maintenance & care is advised to insure years of service of your coated headers.

(!) INSTALLATION TIP TO PROTECT YOUR HEADERS FINISH

Mask areas of header tubes with painters tape to protect the coating from scratches during installation.

TTi HEADER COATING OPTIONS

[Color options: Silver satin, Polished silver, and Black satin*]

1. CERAMIC COATING (Silver satin finish): The main function of ceramic coating is to protect the steel surface against rust and corrosion. Advantages of ceramic coating; increases part life longevity, does not "blue" like chrome, and withstands temperatures up to 1200°F. Note: Exceeding this temperature may/will result in discoloration of the header tubes, turning them a dark gray color.

2. POLISHED CERAMIC COATING (Silver high-luster finish): The initial step in process is the same as the above ceramic coating option. The external coating is then ceramic tumbled as the final step to give the headers/exhaust component that appealing high-luster polished appearance.

3. BLACK CERAMIC COATING (Black satin finish): The initial step in process is the same as the above ceramic coating option to protect the steel surface against rust and corrosion. The external coating is then prepped, and spray with the black colored ceramic coating.

*Black ceramic coating caution: The black satin exterior finish requires careful handling and found to be more delicate than the undercoated silver ceramic coat. If scratched or dinged, the exterior black coating may/will flake, chip or peel.

THERMAL BARRIER: Internal coating is designed to reduce heat which in turn, extends part life by reducing corrosion and thermal fatigue. Thermal barrier keeps under hood temperatures approximately 50°F cooler, which also protects other engine components from heat damage.

Ceramic Coating and Thermal Barrier by Engineered Applications located in Vernon, CA.

4. NICKEL-CHROME PLATED: Decorative chrome plating is a less expensive coating process used to inhibit corrosion and will not provide thermal protection. Nickel-chrome plated parts are much more susceptible to bluing, blistering, peeling, and corrosion due to exhaust temperatures. This process carries no warranty other than to be free from defects at the time of purchase prior to installation only.

Nickel Chrome Plating done by Valley Plating Works, Inc. located in Los Angeles, CA.

MAINTENANCE & CARE

TTi strives to offer the highest quality header coatings available on the market today. However, high performance coatings do require care and maintenance. The following tips are suggested to insure years of service of your Nickel-Chrome, Silver Ceramic Coated, Polished Silver Ceramic Coated, and Stainless Steel Headers.

Helpful hint to extend the life of your Headers and Exhaust System: Exhaust corrosion will occur if moisture (condensation) is not cleared out of the tubes. Make sure that the vehicle is driven at least 20 to 30 minutes whenever the car is started to completely dry out all liquid / acid that is created by the combustion process in the engine. Failure to do so will cause pre-mature rotting of the tubes from the inside out.

(!) Warning First Engine Runs: Header coating damage usually occurs during the first engine run when the exhaust temperatures exceed 1200°F. Excess exhaust temperatures are normally caused by excessively lean or excessively rich air/fuel mixtures and/or incorrect ignition timing. For this reason we strongly suggest that you use an old set of headers or a set of cast iron manifolds for your first engine run / cam break-in. This will insure that you will not damage the coating or void the warranty of your new TTi ceramic-coated headers.

After Header Installation and Before Engine Run: Remove grease and/or skin oils from the header tube surface. Stains & fingerprints will show when header gets hot.

- Nickel Chrome Plated Headers: Wipe down tubes with rubbing alcohol and a soft cloth, dry thoroughly.
- Silver Ceramic Coated, Polished Silver Ceramic Coated and Stainless Headers: Wipe the tubes down with an environmentally safe Orange Cleaner Degreaser or mild soap, warm water and a soft cloth, dry thoroughly.

When storing your car for an extended period of time, some precautions must be taken. Park the car over a large sheet of plastic or tarp. This will protect your car and headers from moisture seeping up through the floor. Wipe down and dry the headers thoroughly. Then coat the headers with WD-40 or an equivalent where the tubes are welded to the header flanges and where the tubes come in close proximity to each other (especially where the four tubes enter into the collector). These areas are prone to rusting, as the coating is unable to get between the tubes in the unexposed areas of the header. If rust occurs, it will travel into and under the coating and create a stain. When you are ready to start the car after storage, wash the WD-40 off by following the cleaning procedures.

Cleaning road grime, oil, grease, and surface deposits (surface rust) created by moisture/water from your header coatings: Use an environmentally safe Orange Cleaner Degreaser, warm water and a soft cloth. Two or Three cleanings may be required. Be sure to dry thoroughly.

For more aggressive header coating cleanings from baked-on oils/fluids, melted-on microfiber towels or plastic grocery bags try a Super-fine "0000" Steel wool pad or use an Ultra-fine Scotch-brite pad. If all else fails, use a high-temp aluminum color spray paint. The color should blend once the header tubes heat up. (High-heat spray paints: Krylon 1402, VHT Flameproof SP117)

Polish compounds to revitalize header coatings

- Silver Ceramic & Polished Silver Ceramic: Nevr-Dull, Mothers PowerMetal or The Wax Shop
- Stainless Steel: Nevr-Dull Wadding Polish
- Nickel Chrome Plating: "Bluing" discoloration is inevitable. You cannot remove it, although there are products that claim to do so like, Blue-Job Chrome Polish.

(!) Polished Silver Ceramic Coating: Unfortunately, you cannot bring back a "High Luster" Polish appearance once stained or discolored.



TUBE TECHNOLOGIES, INC.
1555 Consumer Cir.
Corona, CA 92880-1726
Tel: 951-371-4878
www.ttiexhaust.com

90-DAY LIMITED WARRANTY

Mfg. by Tube Technologies, Inc. (TTi), Corona California

TTi warrants all products to the original purchaser to be sold free of defects in material and workmanship for 90-days from date of purchase. In the event of an alleged defect in material or workmanship contact TTI at (951) 371-4878. Please provide a proof of purchase reference at time of call for quicker look-up. Ex: Invoice #, Packing List # or Sales Order #.

TTi does not warrant products that have been damaged caused by abuse, neglect, accident, improper installation or use on other applications other than recommended by TTI Performance Exhaust and Headers. Under no circumstances will TTI replace, repair or refund any product that has been altered in any way, mutilated or shows evidence of the use of insulating wrap products. TTI will not warranty cost of removal or re-installation of a product or will not be responsible for any shipping charges incurred. TTI will not assume responsibility for mufflers meeting individual customer's preference or the specific sound ordinances in any city, county and/or state. TTI reserves the right to make changes in design, materials and specifications or to make product changes as deemed necessary without prior notice.

RETURN POLICY

Returned merchandise is subject to a 10% restocking fee. TTI does not refund freight. Contact TTI at (951) 371-4878 or the Authorized TTI Distributor from whom the merchandise was purchased through to receive a "Return Merchandise Authorization Number" (RMA #). Proof of purchase required! (Invoice, Packing List or Sales Order #) Return the merchandise along with a copy of your proof of purchase to: TTI Returns Dept. • 1555 Consumer Circle • Corona, CA 92880. Enclose a written reason for the return with a contact phone number and clearly write the RMA # on the outside of the box. Merchandise must be received in resalable condition. Final issuance of credit / refund is subject to receipt and inspection of merchandise by Tube Tech. Inc.

Note: Parts damaged in transit due to insufficient packaging may incur repair charges.

For general packaging guidelines to help prepare your package for safe shipping read our Packaging Guidelines & Procedures.

2-YEAR LIMITED CERAMIC COATING WARRANTY

by Engineered Applications, Vernon California

In the event of an alleged defect in the coating; peeling, chipping, flaking or rusting, complete a "Coating Warranty Return Form" and return it along with parts to: Engineered Applications.

Proof of Purchase required! (Invoice or Packing List)

Final determination of warranty is subject to receipt and inspection of parts by EA. EA will not accept liability for products that have been damaged caused by abuse, neglect, accident, improper installation, shows evidence of insulating wrap products or show evidence of adverse conditions such as; High heat temperatures encountered during engine break-in.

(!) Note: Engineered Applications sole responsibility is strictly to strip-off existing coating, recoat and return it back to you. EA will not warranty any labor related costs.