



TTI Performance Exhaust and Headers  
Tube Technologies, Inc.  
Corona, California 92880-1726  
Phone (951) 371-4878

[www.ttiexhaust.com](http://www.ttiexhaust.com)

Sheet #101 / Footnote #36

### 3-section throttle rod swivel assembly modification

Applications with a 3-section throttle rod may require modification to the bell-crank and the pivot shaft to clear the header tubes or exhaust pipes.

Big Block Headers: Modification may be required when installing some headers.

Exhaust-pipes (to stock manifolds): Modification will be required when installing listed pipes; A25LE, E25LE3 and E30LE3.

1. The bell-crank and the pivot shaft must be shortened by 3/4".
2. Weld the bell-crank back together as shown.
3. Re-bend the lower throttle rod as shown.

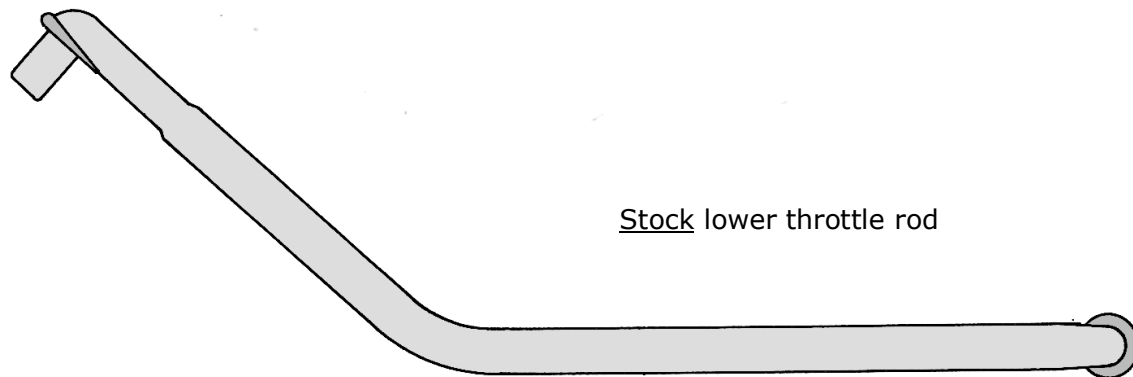
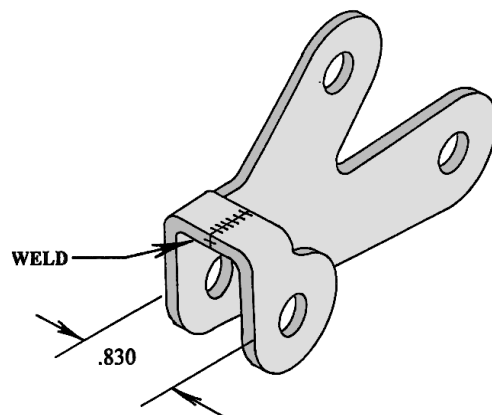

Stock lower throttle rod

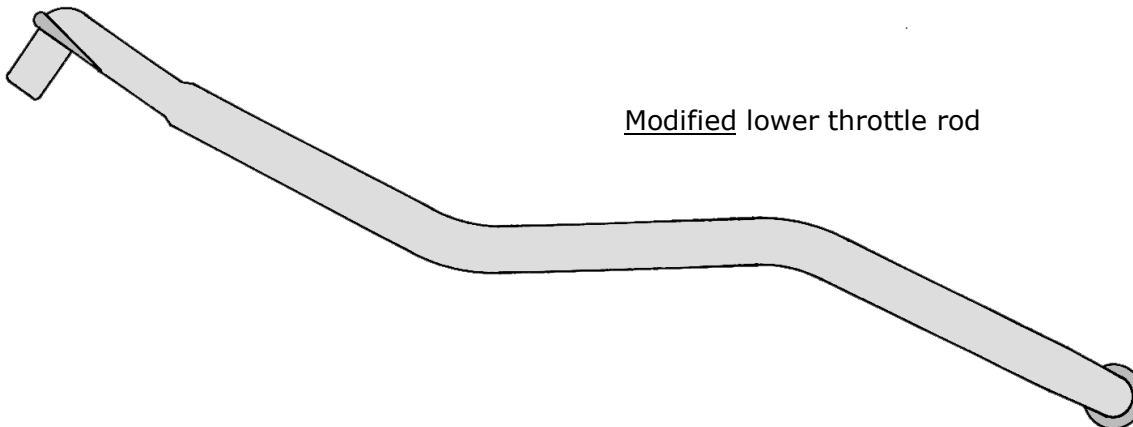

Modified lower throttle rod