



Tube Technologies, Inc.
1555 Consumer Circle
Corona, CA 92880
Ph. (951) 371-4878
www.ttiexhaust.com

Engine Mount Modification (C-body Applications)

Suggested modification of the Engine mounts when pitman arm or idler arm interferes with the header tube. By slotting holes $\frac{1}{2}$ an inch, the engine can be moved toward the rear of the vehicle to achieve clearance of the header tube. The transmission mounts are normally slotted from the factory, but if they are not it will be necessary to slot the mounting holes as well.

Drivers-side

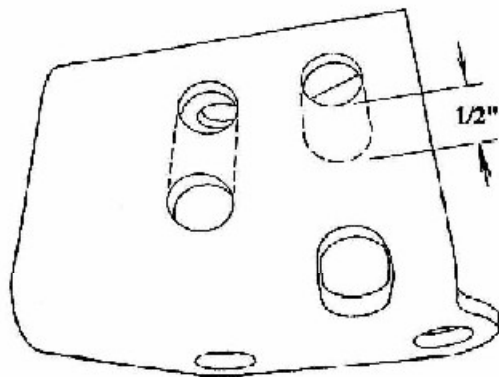

Un-Modified Mount

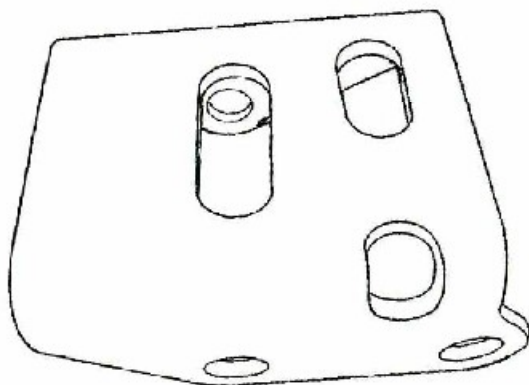

Modified Mount

Passenger-side

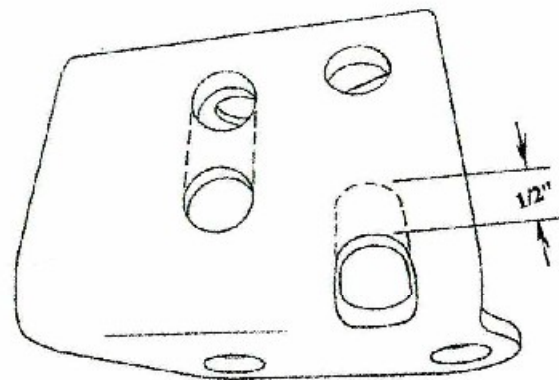

Un-Modified Mount

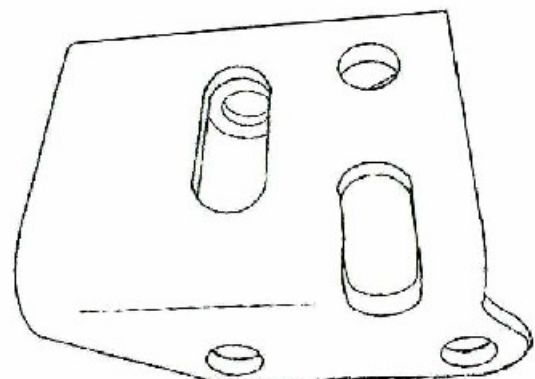

Modified Mount